



US 20040169572A1

(19) **United States**

(12) **Patent Application Publication** (10) **Pub. No.: US 2004/0169572 A1**

**Elmore**

(43) **Pub. Date:**

**Sep. 2, 2004**

(54) **METHOD AND APPARATUS FOR LAUNCHING A SURFACEWAVE ONTO A SINGLE CONDUCTOR TRANSMISSION LINE**

**Publication Classification**

(51) **Int. Cl.<sup>7</sup>** ..... **H01P 3/10**

(52) **U.S. Cl.** ..... **333/240**

(76) **Inventor:** **Glenn E. Elmore**, Santa Rosa, CA (US)

**Correspondence Address:**  
**JOHNSON & STAINBROOK, LLP**  
**Suite 203**  
**3550 Round Barn Blvd.**  
**Santa Rosa, CA 95403 (US)**

(57) **ABSTRACT**

An apparatus for launching a surfacewave onto a single conductor transmission line provides a launch including a flared, continuously curving cone portion; a coaxial adapter portion; a wire adapter portion for contacting the wire conductor which allows for a multiplicity of wire dimensions for either insulated or uninsulated wire, or a tri-axial wire adapter device enabling non-contacting coupling to a wire; and a longitudinal slot added to the flared cone, wire adapter, and coaxial adapter portions of the launch to allow direct placement of the launch onto existing lines, without requiring cutting or threading of those lines for installation.

(21) **Appl. No.:** **10/732,080**

(22) **Filed:** **Dec. 9, 2003**

**Related U.S. Application Data**

(60) **Provisional application No. 60/432,099**, filed on Dec. 9, 2002.

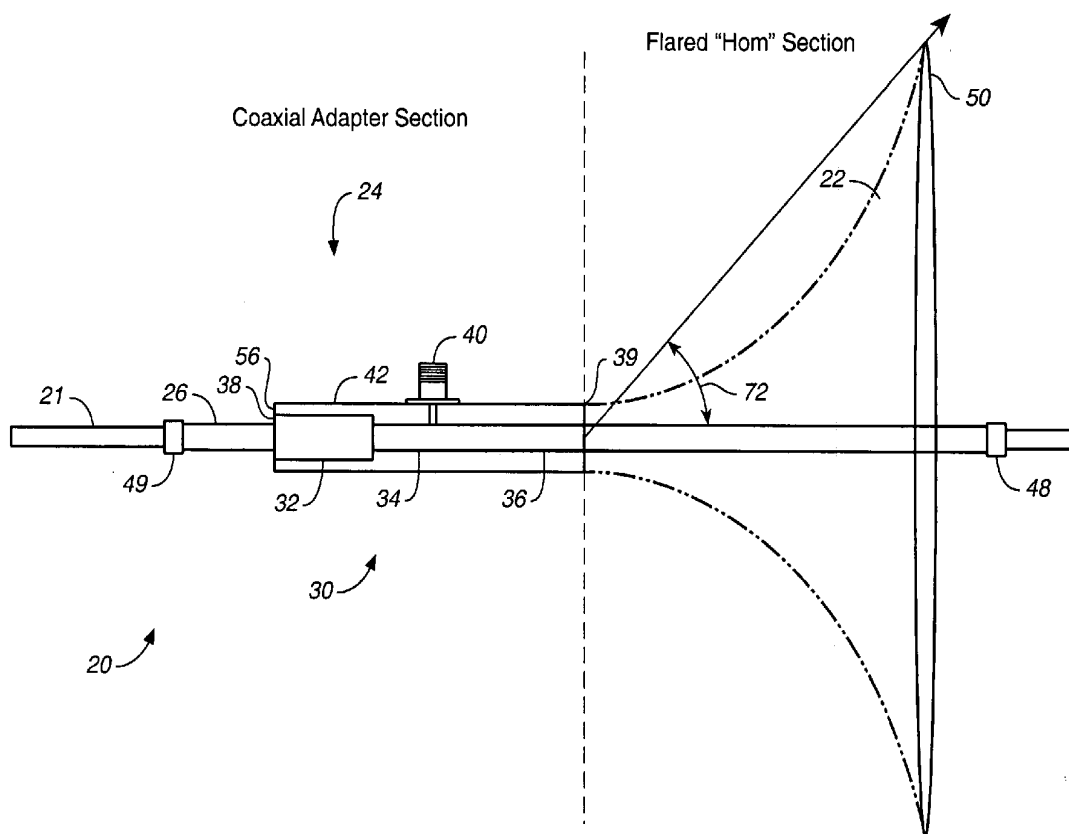

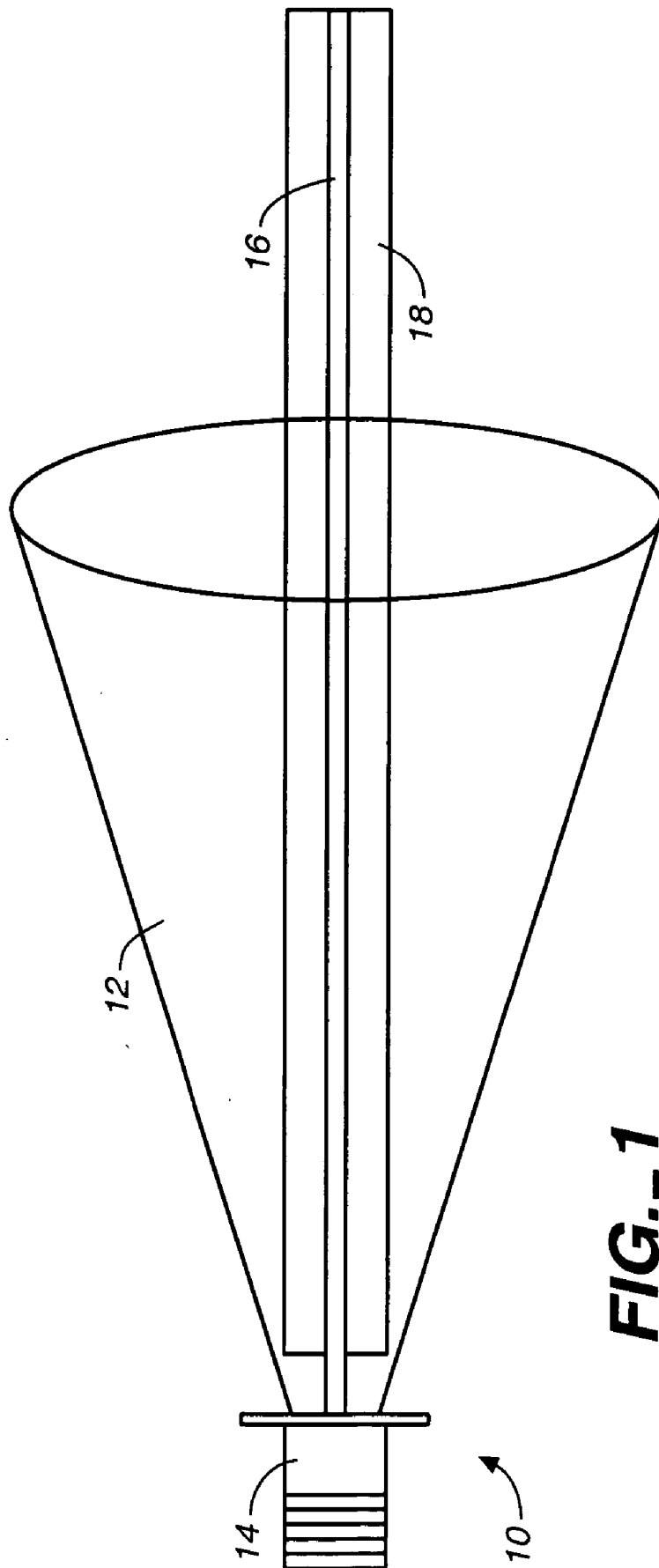

**FIG.- 1**

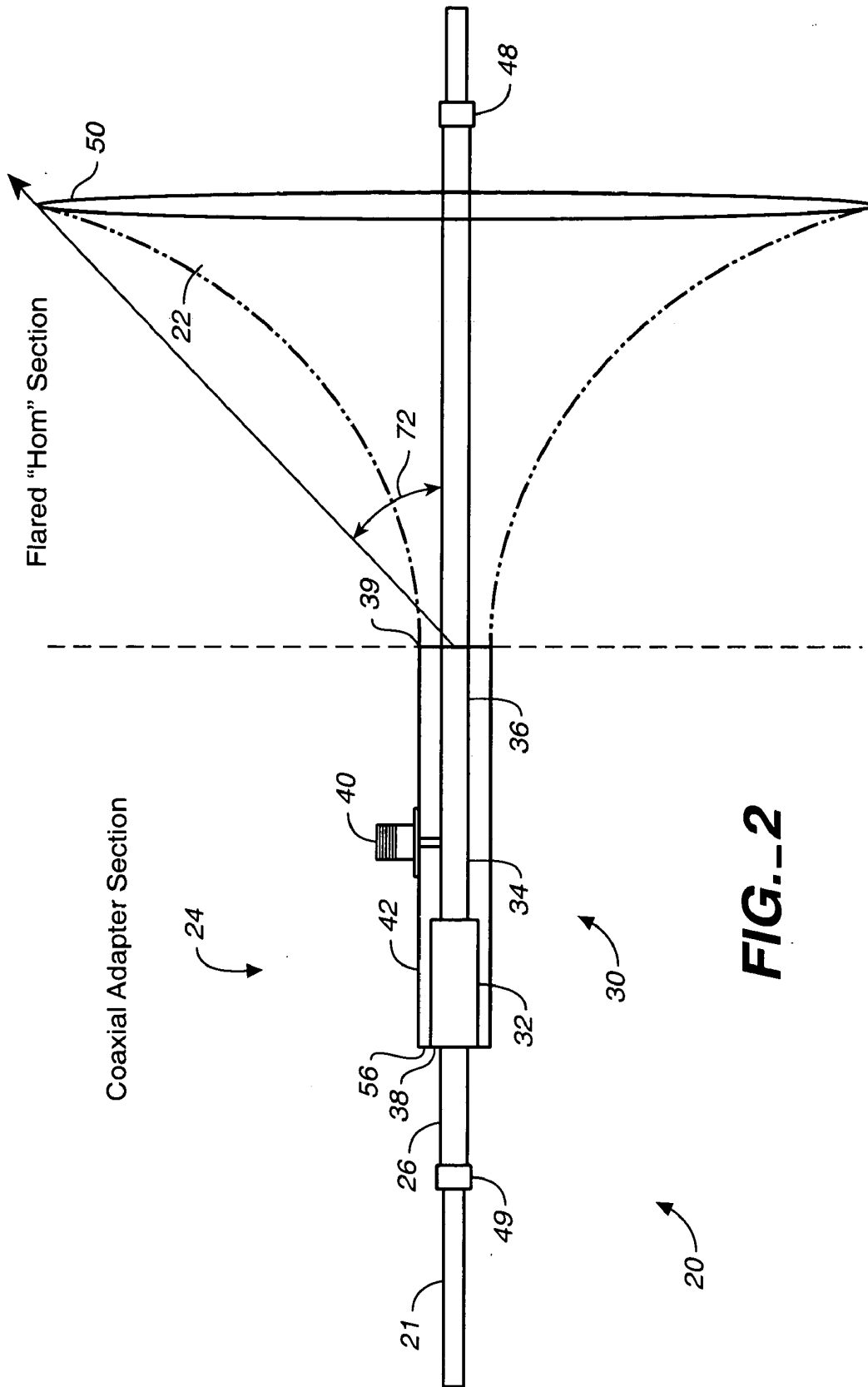
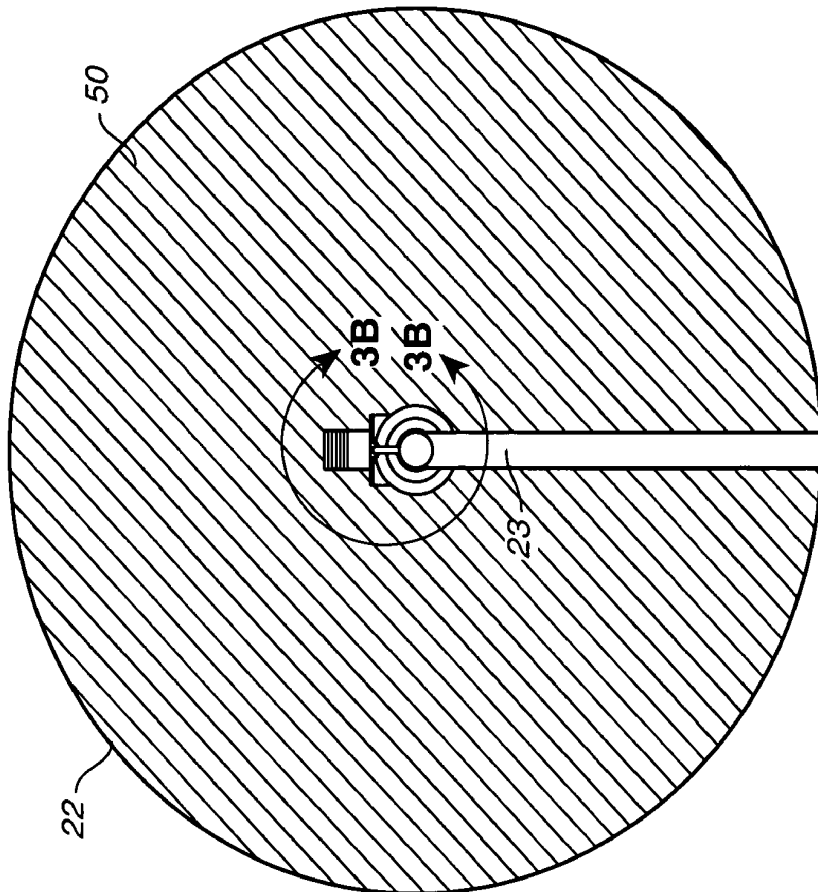
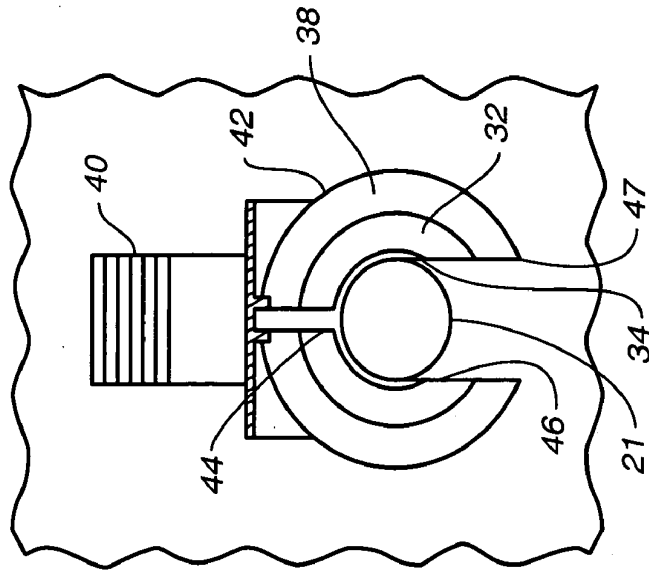

FIG. 2



**FIG. 3A**



**FIG. 3B**

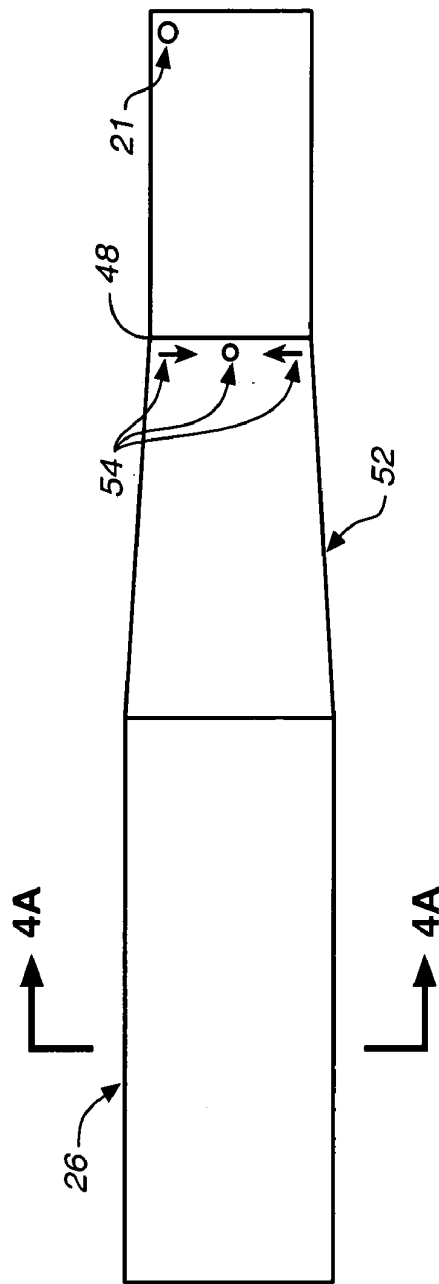

**FIG. 4B**

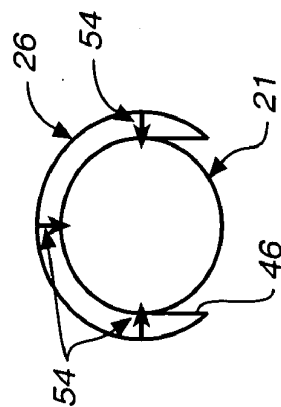

**FIG. 4A**

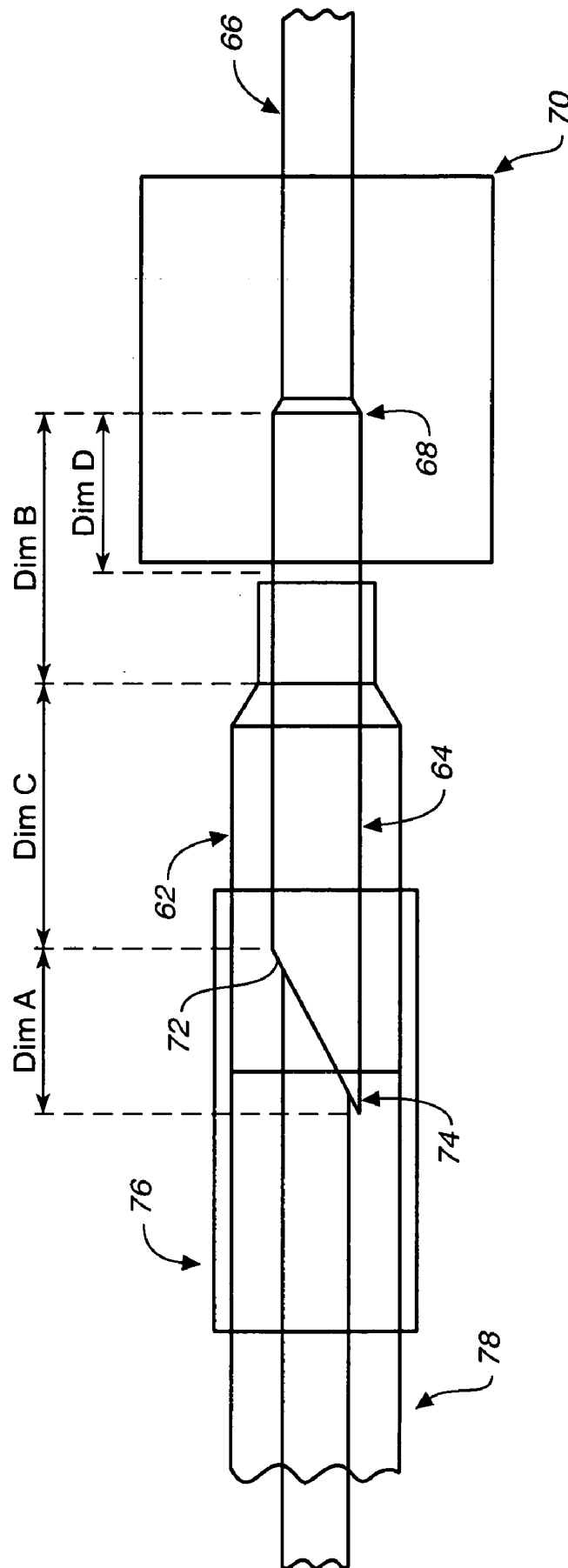

**FIG. 5**

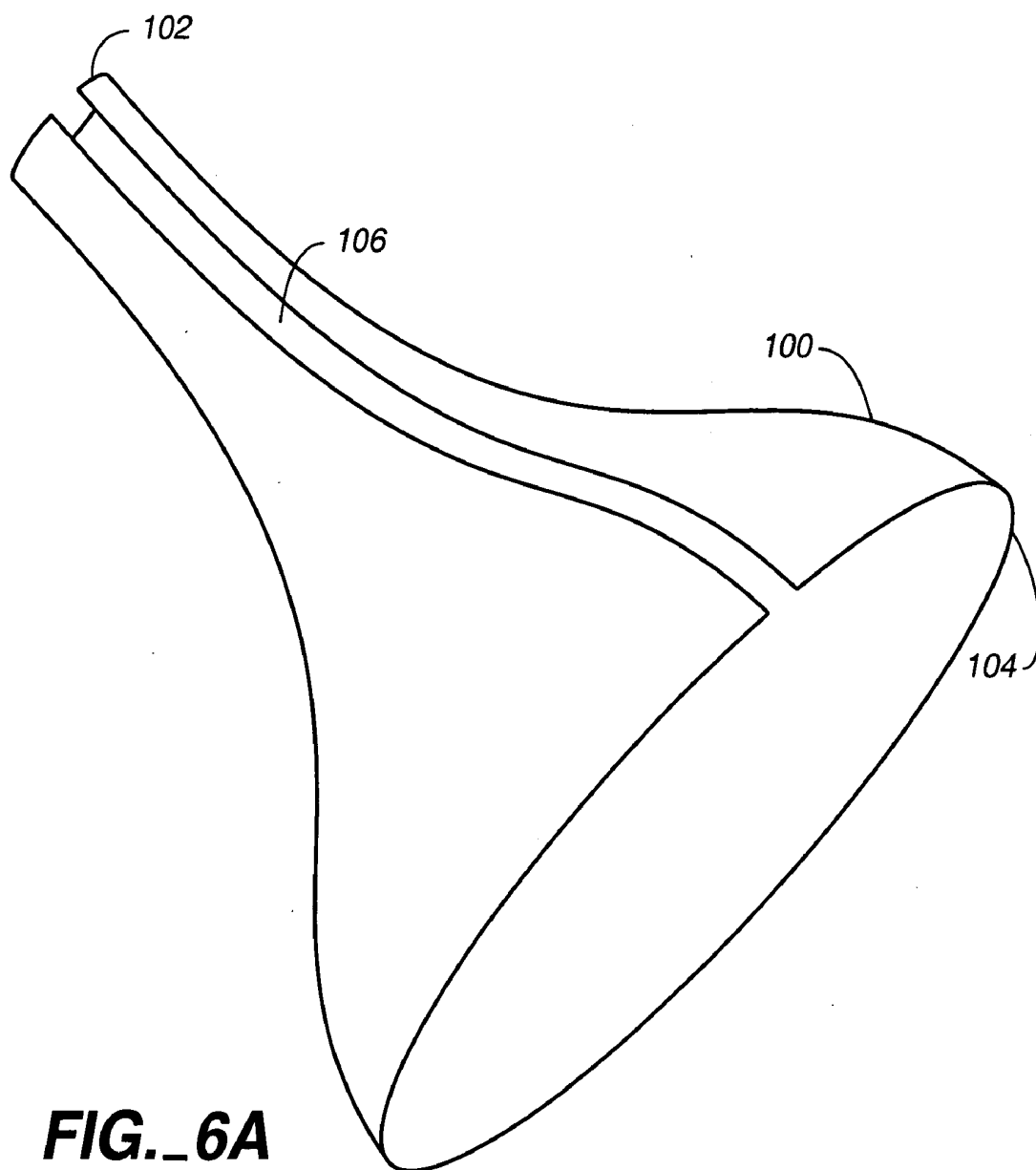

**FIG. 6A**

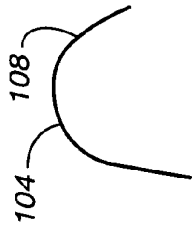

**FIG. 6C**

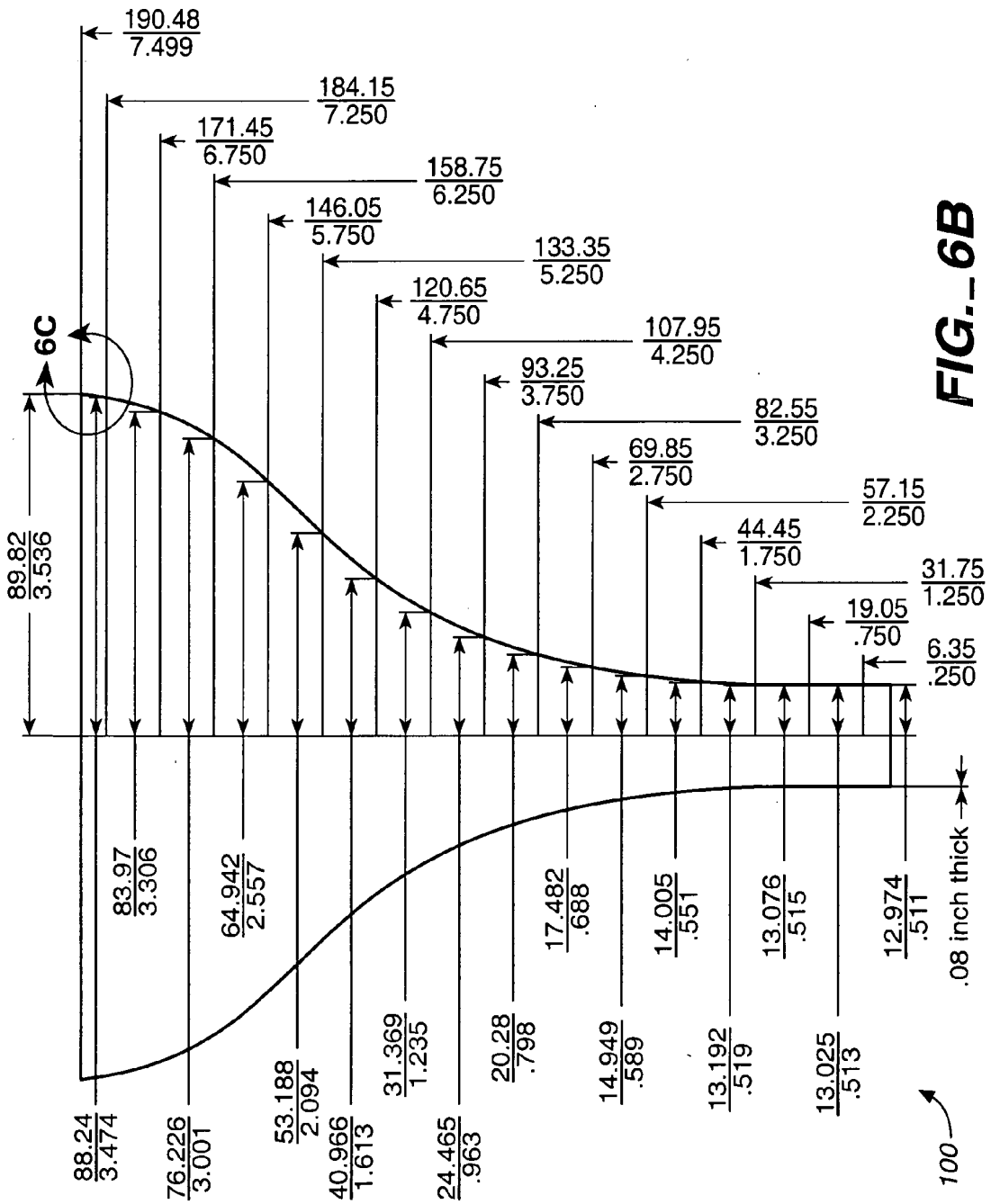

**FIG. 6B**



## METHOD AND APPARATUS FOR LAUNCHING A SURFACEWAVE ONTO A SINGLE CONDUCTOR TRANSMISSION LINE

### CROSS REFERENCE TO RELATED APPLICATIONS

[0001] The present application claims the benefit of the filing date of U.S. Provisional Patent Application, Ser. No. 60/432,099, filed 09 Dec. 2002.

### STATEMENT REGARDING FEDERALLY SPONSORED RESEARCH OR DEVELOPMENT

[0002] Not applicable.

### REFERENCE TO A MICROFICHE APPENDIX

[0003] Not applicable.

### TECHNICAL FIELD

[0004] The present invention relates generally to methods and apparatus for surfacewave transmission, and more particularly to an improved method and apparatus for launching a surfacewave onto a single wire transmission line.

[0005] The present invention improves the performance and utility of previous launch devices for converting coaxial mode transmission to and from surfacewave mode transmission on a single conductor transmission line. This technology is related to transmission lines made from single conductor line having a thick outer dielectric sheath, an insulated wire, and known as a "Gobau line", "G-line", SWTL (surface wave transmission line), or "singlewire", and is also related to lines made using thinly insulated conductors, as well as completely uninsulated conductors having no outer dielectric sheath at all. It includes conductors fabricated from multiple parallel strands, twisted or untwisted, and either insulated from each other or contacting each other, as well as single solid conductors of elliptical or rectangular cross-section.

### BACKGROUND INFORMATION AND DISCUSSION OF RELATED ART

[0006] Previous launch devices for single conductor transmission lines have used a simple conical shape structure to excite the surfacewave mode onto an insulated single conductor transmission line. In addition to having excess transmission attenuation due to losses in the dielectric insulation, these designs suffer from significant impedance mismatch, unwanted conversion to radiating modes and resultant transmission attenuation of the surfacewave mode when a broad range of frequencies is supported, and require both a longer cone and wider cone mouth in order to excite a surfacewave mode onto the single conductor. Special effort is also required to mount these previous designs onto the conductor, requiring that the transmission line be broken so that the launch may be threaded onto the line in order to be attached. This presents both mechanical and electrical challenges and limitations to the designer and installer of such a device, particularly if the launch apparatus is to be installed onto a pre-existing single conductor line.

[0007] The foregoing reflects the current state of the art of which the present inventor is aware. Reference to, and discussion of, this art is intended to aid in discharging

Applicant's acknowledged duty of candor in disclosing information that may be relevant to the examination of claims to the present invention. However, it is respectfully submitted that none of the prior art discloses, teaches, suggests, shows, or otherwise renders obvious, either singly or when considered in combination, the invention described and claimed herein.

### BRIEF SUMMARY OF THE INVENTION

[0008] The present invention provides a method and apparatus for launching a surfacewave onto a single conductor transmission line. The inventive apparatus provides launch of a surfacewave onto either insulated or uninsulated single conductors making application to a variety of existing lines not only practical, but simpler and more economical. This furthers the use of existing lines, such as high tension power main wires, for surfacewave mode transmission of UHF and microwave energy. Previous known references and teachings on the subject have restricted usage to insulated wires.

[0009] The invention includes a flared cone portion constructed of either a continuously curving "horn" or a combination of two or more straight conical sections of different flare angle approximating a curved structure, providing improved impedance match, improved broadband and multi-band transmission performance and improved conversion to surfacewave mode with a physically smaller horn section when compared to prior, single conical section designs.

[0010] The invention further includes a coaxial adapter portion which adapts conventional coaxial transmission cable to the coaxial transmission line mode which is present at the narrow end of the cone or horn section of the launch, and which can function simultaneously on two different frequency ranges separated by more than an octave.

[0011] A first embodiment of the invention provides a wire adapter device for contacting the wire conductor which allows for a multiplicity of wire dimensions for either insulated or uninsulated wire. A second embodiment provides a tri-axial wire adapter device enabling non-contacting coupling to a wire.

[0012] The invention also provides a longitudinal slot incorporated into to the flared cone, wire adapter, and coaxial adapter sections of the launch which allows simple and easy placement of the launch onto existing lines, and requires no cutting or threading of those lines for installation. Use of such a slot is not inconsistent with good electrical characteristics of the launch.

[0013] It is therefore an object of the present invention to provide a new and improved surfacewave launch apparatus.

[0014] It is another object of the present invention to provide a new and improved surfacewave launch adapted for use on insulated or uninsulated single conductors.

[0015] A further object or feature of the present invention is a new and improved flared cone apparatus with improved broadband and multiband transmission performance.

[0016] An even further object of the present invention is to provide a novel coaxial adapter for conventional coaxial transmission cable.

[0017] A still further object of the present invention is to provide an improved wire adapter for contacting a wire conductor.

[0018] An additional object of the present invention is to provide an improved method for placement of a surfacewave launch on an existing line.

[0019] Other novel features which are characteristic of the invention, as to organization and method of operation, together with further objects and advantages thereof will be better understood from the following description considered in connection with the accompanying drawings, in which preferred embodiments of the invention are illustrated by way of example. It is to be expressly understood, however, that the drawings are for illustration and description only and is not intended as a definition of the limits of the invention. The various features of novelty which characterize the invention are pointed out with particularity in the claims annexed to and forming part of this disclosure. The invention resides not in any one of these features taken alone, but rather in the particular combination of all of its structures for the functions specified.

[0020] There has thus been broadly outlined the more important features of the invention in order that the detailed description thereof that follows may be better understood, and in order that the present contribution to the art may be better appreciated. There are, of course, additional features of the invention that will be described hereinafter and which will form additional subject matter of the claims appended hereto. Those skilled in the art will appreciate that the conception upon which this disclosure is based readily may be utilized as a basis for the designing of other structures, methods and systems for carrying out the several purposes of the present invention. It is important, therefore, that the claims be regarded as including such equivalent constructions insofar as they do not depart from the spirit and scope of the present invention.

[0021] Further, the purpose of the Abstract is to enable the U.S. Patent and Trademark Office and the public generally, and especially the scientists, engineers and practitioners in the art who are not familiar with patent or legal terms or phraseology, to determine quickly from a cursory inspection the nature and essence of the technical disclosure of the application. The Abstract is neither intended to define the invention of this application, which is measured by the claims, nor is it intended to be limiting as to the scope of the invention in any way.

[0022] Certain terminology and derivations thereof may be used in the following description for convenience in reference only, and will not be limiting. For example, words such as "upward," "downward," "left," and "right" would refer to directions in the drawings to which reference is made unless otherwise stated. Similarly, words such as "inward" and "outward" would refer to directions toward and away from, respectively, the geometric center of a device or area and designated parts thereof. References in the singular tense include the plural, and vice versa, unless otherwise noted.

#### BRIEF DESCRIPTION OF THE SEVERAL VIEWS OF THE DRAWINGS

[0023] The invention will be better understood and objects other than those set forth above will become apparent when consideration is given to the following detailed description thereof. Such description makes reference to the annexed drawing wherein:

[0024] **FIG. 1** is a schematic view of a prior art surface-wave launch device;

[0025] **FIG. 2** is a side elevation cross-sectional view of a first embodiment of an improved surfacewave launch apparatus of this invention;

[0026] **FIG. 3A** is an end elevation view of the surface-wave launch of **FIG. 2**, while **FIG. 3B** is an enlarged end elevation view of the coaxial adapter and wire adapter portions of the surfacewave launch of **FIG. 3A**;

[0027] **FIG. 4A** is an end elevation view of a wire adapter of this invention as installed on a single wire conductor, while **FIG. 4B** is a top view of a wire adapter as installed on a single wire conductor, showing the taper to the single wire conductor;

[0028] **FIG. 5** is a side elevation cross-sectional view of an alternate dualband embodiment for a coaxial adapter of this invention; and

[0029] **FIG. 6A** is a perspective view of the flared horn portion of an alternate embodiment of the surfacewave launch of this invention; while **FIG. 6B** is a cross-sectional view of the flared horn of **FIG. 6A**, and **FIG. 6C** is a detail view of an optional rolled edge for the outer mouth of the flared horn.

#### DETAILED DESCRIPTION OF THE INVENTION

[0030] **FIG. 1** is a schematic view of a prior art surface-wave launch device **10**. Prior art surfacewave launch **10** includes conical launch **12** and coaxial connector **14**, both connected to wire conductor **16** covered by an outer dielectric sheath **18**. Mounting of the prior art launch device **10** requires that wire **16** be broken, so that the launch may be threaded on. This presents both mechanical and electrical problems to the installer of such a device, particularly if the launch is to be installed onto a pre-existing single conductor line.

[0031] Referring to **FIGS. 2 through 6C**, wherein like reference numerals refer to like components in the various views, there is illustrated therein a new and improved surfacewave launch apparatus of this invention.

[0032] **FIG. 2** is a side elevation cross-sectional view of a first embodiment of the improved apparatus **20** for launching a surfacewave onto a single conductor transmission line **21** (either with or without an outer dielectric covering). Surfacewave launch **20** includes a flared horn or cone portion **22**, a coaxial adapter portion **24**, and a wire adapter portion **26**.

[0033] The entire launch device may be cast or formed from a single piece of metal if desired. However, for the purpose of this description, construction of the inventive apparatus will be divided into sections for clarity as follows: (a) the construction of the coaxial adapter; (b) the construction of the flared cone or "horn"; and (c) the construction of the wire adapter. Construction here is described for use with coaxial connections with 50 ohm characteristic impedance, but other designs are possible by modifying the dimensions. Similarly, this description shows a launch apparatus designed to operate simultaneously on two US ISM bands centered around 2.44 GHz. and 5.3 GHz. Other choices are

possible by changing the dimensions of the multiband choke sections and the size of the open end of the flared cone, as is well known in the art.

[0034] In the first embodiment of the improved surface-wave launch apparatus of this invention, as depicted in **FIGS. 2 through 4**, construction of the coaxial adapter portion **24** consists of the multiband choke sections **30**, comprised of a 19 ohm section **32**, a 50 ohm section **34**, and another 50 ohm extension section **36**, along with a shorting end **38** (opposite non-shortend end **39**) and a mounted coaxial connector **40**. The coaxial connector **40** is mounted with its outer (ground) connection attached to the outer sleeve **42** which is provided with a hole for the connector pin **44** or inner conductor to pass through. The pin extends into the inside of the sleeve **42** and makes low impedance electrical contact with the wire adapter **26**. The flared horn **22**, wire adapter **26**, and coaxial adapter **24** each include a longitudinal slot **23**, **46**, and **47**, respectively, provided for mounting onto the single conductor line without breaking the line. The lower impedance choke section **32**, approximately 19 ohms, is created by increasing the outer diameter of the wire adapter over a portion of the distance between the connector pin **44** and the end short **38**. The inner diameter of the coaxial sleeve and the outer diameter of the wire adapter are chosen to provide the required impedances.

[0035] The wire adapter **26** shown here makes electrical contact with the single wire conductor **21** at downstream terminus **48** beyond the mouth **50**, the widest dimension of the flare on the flared cone **22**, effectively providing an electro-mechanical attachment to the wire at that point. The other wire adapter terminus **49** is preferably only a mechanical attachment.

[0036] **FIGS. 4A and 4B** illustrate the wire adapter **26** as installed on a single wire conductor **21**. This connection is required to provide a low impedance between the wire adapter and the single conductor wire across both operating bands of the launch. It is desirable for the wire adapter **26** to be as thin as is mechanically practical since its dimensions decrease the impedance at the mouth of the flared cone. Additionally, there is an impedance discontinuity at the terminus **48** of the wire adapter **26** which is minimized when the step in diameter between the wire adapter and the wire is small. Tapering the end of the wire adapter, as along tapered section **52**, helps minimize this discontinuity. The length of the taper is preferably at least a quarter wave at the lowest operating frequency.

[0037] Direct electrical contact between the terminus **48** of the wire adapter and the wire **21** is provided by metal contacts such as "tacks" **54** which are driven through the wire adapter **26**, through any dielectric which is present, and into the wire conductor. These tacks may be further secured with a dielectric compression band of the "TyWrap" variety.

[0038] Good electrical contact is also required among the end short **38**, the end **56** of the outer sleeve **42** and the wire adapter **26**. Copper, brass and aluminum are all reasonable candidates for the construction of these coaxial adapter portion components. For lowest losses, copper or silver should be plated onto the current carrying surfaces or used for the entire coaxial adapter portion **24** and wire adapter portion **26**.

[0039] **FIG. 5** is a side elevation cross-sectional view of an alternate dualband embodiment for a coaxial adapter **60**

of this invention. This embodiment utilizes a triaxial structure providing a bushing/triax outer conductor **62**, a triax intermediate conductor **64**, and using the single conductor/triax center line **66** as the third and central conductor of the assembly. This method allows coupling to and launching of the surfacewave mode onto the central line but requires only a single electrical and mechanical contact onto that line, i.e., shorting point **68** located at the end, shorting block **70**. Two separate coaxial cavities are formed, one between the intermediate line **64** and the central line **66**, and a second between the outer conductor **62** and the intermediate line **64**. The intermediate line **64** is tapered at the open end **72** where the coaxial cable contact is made at connection **74**. Coupling **76** couples the adapter section to the narrow end **78** of the flared horn. The two coaxial cavities, along with the tapered line provide good coupling to the central line across two separate bands without requiring any physical contact which could be problematic for outdoor use due to environmental concerns.

[0040] For the construction of the flared cone section in both embodiments, the cone or "horn" section may be cast or formed from either metal or from a non-conducting material and metalized after fabrication. As for the coaxial adapter section, for lowest losses copper or silver should be plated onto the current carrying surfaces or used directly for the entire interior of the flared cone section.

[0041] While the flared cone may be fabricated from multiple flat sheet metal subsections to approximate the desired exponential tapered shape, the preferred method of construction is to create a three-dimensional curved surface which exactly represents the desired exponential taper. This taper is such that the resulting impedance of the coaxial line formed by the flared cone outer conductor and the wire adapter inner conductor ranges from the coaxial adapter extension section impedance (50 ohms) to a higher impedance which is that of a coaxial line having an outer conductor inner dimension the same as the mouth of the flared cone, and an inner conductor of the same dimensions as the wireless adapter.

[0042] In the first embodiment of **FIGS. 2 and 3**, the flared cone diameter is exponentially tapered between these two end limits, as shown. The flare angle **72** of the flared cone **22** (**FIG. 2**), measured from the non-shortend end **39** of the coaxial adapter portion **24** to the center of the opening, is preferably between 40 and 60 degrees. The higher impedance at the mouth **50** of the flared cone **22**, as described above, should be as high as possible, and preferably over 200 ohms. This prescribes a minimum diameter for the flared cone mouth **50**.

[0043] In the second embodiment illustrated in **FIG. 6**, the diameter throughout the midsection of the flared cone **100** is substantially exponentially tapered while the change of taper at the ends (narrow end **102** and mouth **104**) falls to zero. This arrangement can improve the broadband characteristics of the launch. To arrive at particular dimensions, it is useful to consider the entire cone from the perspective of a broadband coaxial line matching transformer. As with the first embodiment of **FIGS. 2 and 3**, the higher impedance at the mouth **104** of the flared cone **100** should be as high as possible, and preferably over 200 ohms. **FIG. 6B** shows the dimensions of this second embodiment. Also analogous to the flared cone of the first embodiment, the cone **100** includes a longitudinal slot **106** enabling direct mounting onto a wire.

[0044] As detailed in FIG. 6C, the edge 108 of the outer mouth 104 of the flared horn may be rolled smoothly rather than simply terminating. This can be advantageous for reducing surfacewave to radiated mode conversion and improving transmission characteristics of the surfacewave mode.

[0045] Construction of the wire adapter and end short is also different for the two embodiments. In the first embodiment of FIGS. 2 and 3, the wire adapter 26 serves to allow a variety of wire shapes and sizes to be used with the launch. The wire adapter 26 serves to “build up” the dimensions of whatever wire is being used in order to create a 50 ohm coaxial transmission line section no matter what type of wire is being used. It also serves as a means for making a low impedance connection to the wire and to provide mechanical mounting and robustness to the launch. Although not described here, it should be noted that it is also possible to create a low impedance UHF or microwave connection to the wire without actually contacting the wire through the use of open quarterwave choke sections which use either the wire dielectric or an additional dielectric between the wire adapter and the wire conductor.

[0046] For the case where circular wire is being adapted, the wire adapter 26 may have a circular internal shape, exclusive of the longitudinal slot 46, in which the circular single wire lays (see FIGS. 3B and 4A). For this case, the wire adapter 26 may be constructed by cutting copper tubing lengthwise with a band saw. The end short 38 may be constructed from a copper disk, slightly larger than the outer diameter of the outer sleeve 42, and providing a hole of the same diameter as the wire adapter outer diameter (see FIGS. 2 and 3B).

[0047] In the second embodiment (FIG. 5), no physical contact is required, so it is possible to accommodate multiple wire diameters by simply providing different hole diameters in the end, shorting block 68. The electrical design of the dual coaxial cavity structure is tolerant of considerable variation in line size without a great deal of sacrifice in performance. For radically different central wire diameters, it may be necessary to modify the dimensions of the coaxial cavities as well as the flared horn.

[0048] Assembly of the launch also differs with the two embodiments. For the first embodiment (FIGS. 2 through 4), a hole the diameter of the coaxial connector pin 44 is provided in the wire adapter 26. The coaxial connector 40 is first soldered to the outer sleeve 42 and then while the wire adapter 26 is held in position, the center pin may be placed in the hole and soldered. This assembly is then soldered together with the 19 ohm section 32 and the end short 38, completing the coaxial adapter section 24. The flared cone 22 may then be soldered to the non-shortened end 39 of the coaxial section.

[0049] Depending upon requirements, mechanical strength and hermeticity may be improved by filling the flared cone 22 and coaxial adapter 24 with a low loss, low dielectric constant material. However, if this is done, dimensions may have to be modified to achieve the desired impedances.

[0050] For the first embodiment of the launch, as shown in FIGS. 2 through 4, dimensions and materials may be as follows:

Flared Horn Length	3.5 inch
Flared Horn Mouth Diameter	3.5 inch
Outer Sleeve Inner Diameter	.60 inch
Wire Adapter Outer Diameter	.26 inch
Wire Adapter Length	8.0 inch
Single Wire Diameter	.23 inch
19 ohm section Diameter	.44 inch
19 ohm section length	.91 inch
50 ohm section Diameter	.26 inch
50 ohm section length	.61 inch
50 ohm extension length	1.4 inch
Coaxial Connector	type SMA or N

[0051] All material except for the connector is copper.

[0052] For the second embodiment of the launch, as shown in FIGS. 5 and 6, dimensions and materials may be as follows:

Flared Horn Length	3.5 inch
Flared Horn Mouth Diameter	7 inch
Coupling	1" US Schedule L copper coupling
Bushing	1" to 1/2" US Schedule L copper bushing
Triax Intermediate Conductor	1/2" US Schedule L copper pipe
End, Shorting Block	Aluminum
Central Wire Diameter	.25 to .32 inch
Coaxial Connector	type SMA or N
Dimension A	1.78 inch
Dimension B	1.40 inch
Dimension C	.85 inch
Dimension D	.75 inch

[0053] The completed surfacewave launch may be mounted to an existing single wire conductor as follows. For the first embodiment, illustrated in FIGS. 2 through 4, the wire adapter attachment devices (metal contacting tabs 54) are first installed to establish good electrical contact and mechanical robustness. A dielectric compression band (e.g. “TyWrap”) may be used to further secure the wire adapter to the wire. Dielectric filler or covering may be inserted into the flared horn to meet environmental requirements. For the second embodiment, illustrated in FIG. 5, the end, shorting block 68 is drilled to form a bore to fit the wire, and is mounted in sandwich or clamshell fashion around the wire.

[0054] After mounting the device the singlewire transmission line may be used over the entire frequency and band ranges supported just as other types of transmission lines fitted with coaxial connectors would be. Transmitters, receivers, filters and frequency selective devices may be added external to the device and connected to the coaxial connector to suit the desired application. Although shown in the figures as a coaxial cable connector, this connector may also be for direct connection to electronic circuitry located immediately adjacent to the coaxial section of the inventive launch, thus allowing the launch to be part of an integrated communications assembly.

[0055] Accordingly, the present invention may be characterized as a launch apparatus for launching a surfacewave onto a single conductor transmission line, the launch apparatus comprising a flared cone portion; a coaxial adapter portion connected to the flared cone portion; a wire adapter portion for coupling the coaxial adapter portion to the line;

and a longitudinal slot in the flared cone portion, coaxial adapter portion, and wire adapter portion to enable direct placement of the launch apparatus onto the line for installation.

[0056] Alternatively, the invention may be characterized as a method for launching a surfacewave onto a single conductor transmission line, the method comprising the steps of providing a launch apparatus having a flared cone portion, a coaxial adapter portion connected to the flared cone portion, and a wire adapter portion for coupling the coaxial adapter portion to the line; providing a longitudinal slot in the flared cone portion, coaxial adapter portion, and wire adapter portion; and placing the launch apparatus over the line for installation.

[0057] The above disclosure is sufficient to enable one of ordinary skill in the art to practice the invention, and provides the best mode of practicing the invention presently contemplated by the inventor. While there is provided herein a full and complete disclosure of the preferred embodiments of this invention, it is not desired to limit the invention to the exact construction, dimensional relationships, and operation shown and described. Various modifications, alternative constructions, changes and equivalents will readily occur to those skilled in the art and may be employed, as suitable, without departing from the true spirit and scope of the invention. Such changes might involve alternative materials, components, structural arrangements, sizes, shapes, forms, functions, operational features or the like.

[0058] Therefore, the above description and illustrations should not be construed as limiting the scope of the invention, which is defined by the appended claims.

What is claimed as invention is:

1. A launch apparatus for launching a surfacewave onto a single conductor transmission line, said launch apparatus comprising:

a flared cone portion;

a coaxial adapter portion connected to said flared cone portion;

a wire adapter portion for coupling said coaxial adapter portion to the line; and

a longitudinal slot in said flared cone portion, coaxial adapter portion, and wire adapter portion to enable direct placement of said launch apparatus onto the line for installation.

2. The launch apparatus of claim 1 wherein said flared cone portion comprises a continuously curving horn.

3. The launch apparatus of claim 1 wherein said flared cone portion comprises a three-dimensional curved surface.

4. The launch apparatus of claim 1 wherein said flared cone portion includes a pair of ends, and said flared cone portion is exponentially tapered between said pair of ends.

5. The launch apparatus of claim 4 wherein the taper proximate said pair of ends falls to zero.

6. The launch apparatus of claim 1 wherein said flared cone portion has a flare angle of between 40 and 60 degrees.

7. The launch apparatus of claim 1 wherein said coaxial adapter portion includes a multiband choke section.

8. The launch apparatus of claim 1 wherein said coaxial adapter portion includes a mounted coaxial connector bearing a pin to make low impedance electrical contact with said wire adapter portion.

9. The launch apparatus of claim 1 wherein said coaxial adapter portion includes a triaxial structure providing an outer conductor, an intermediate conductor, and a central conductor.

10. The launch apparatus of claim 9 wherein said coaxial adapter portion central conductor comprises the transmission line.

11. The launch apparatus of claim 1 wherein said coaxial adapter portion includes a single electrical and mechanical contact onto the transmission line.

12. The launch apparatus of claim 11 wherein said single electrical and mechanical contact comprises a shorting block.

13. The launch apparatus of claim 12 wherein said shorting block includes a bore sized to fit the transmission line, and is mounted around the transmission line.

14. The launch apparatus of claim 1 wherein said coaxial adapter portion includes two separate coaxial cavities.

15. The launch apparatus of claim 1 wherein said wire adapter portion includes a tapered section to minimize discontinuity with the transmission line.

16. The launch apparatus of claim 1 wherein said wire adapter portion includes metal contacts with the transmission line.

18. The launch apparatus of claim 1 wherein said flared cone portion is constructed of metal.

19. The launch apparatus of claim 1 wherein said coaxial adapter portion is constructed of metal.

20. The launch apparatus of claim 1 wherein said wire adapter portion is constructed of metal.

21. A method for launching a surfacewave onto a single conductor transmission line, said method comprising the steps of:

providing a launch apparatus having a flared cone portion, a coaxial adapter portion connected to said flared cone portion, and a wire adapter portion for coupling said coaxial adapter portion to the line;

providing a longitudinal slot in said flared cone portion, coaxial adapter portion, and wire adapter portion; and

placing said launch apparatus over the line for installation.

22. The method for launching a surfacewave onto a single conductor transmission line of claim 21 further including the step of providing an electrical and mechanical contact onto the transmission line.

23. The method for launching a surfacewave onto a single conductor transmission line of claim 22 wherein said step of providing an electrical and mechanical contact onto the transmission line comprises providing metal contacts with the line.

24. The method for launching a surfacewave onto a single conductor transmission line of claim 22 wherein said step of providing an electrical and mechanical contact onto the transmission line comprises providing a shorting block around the line.

25. The method for launching a surfacewave onto a single conductor transmission line of claim 21 wherein said step of

providing a launch apparatus includes the step of tapering the wire adapter to reduce impedance and minimize discontinuity with the wire.

**26.** The method for launching a surfacewave onto a single conductor transmission line of claim 21 wherein said step of providing a launch apparatus includes the step of providing a coaxial adapter having a triaxial structure.

**27.** The method for launching a surfacewave onto a single conductor transmission line of claim 26 wherein said step of providing a coaxial adapter having a triaxial structure includes forming two separate coaxial cavities.

**28.** The method for launching a surfacewave onto a single conductor transmission line of claim 27 wherein said step of

providing a coaxial adapter having a triaxial structure includes tapering the adapter where contact is made with the line.

**29.** The method for launching a surfacewave onto a single conductor transmission line of claim 21 wherein said step of providing a flared cone comprises constructing a cone from metal.

**30.** The method for launching a surfacewave onto a single conductor transmission line of claim 21 wherein said step of providing a flared cone comprises constructing a cone from metalized non-conducting material.

\* \* \* \* \*